

(No Model.)

2 Sheets—Sheet 1.

M. LEIST.

AUTOMATIC CENTERING OR PIVOTING DRILL.

No. 547,726.

Patented Oct. 8, 1895.

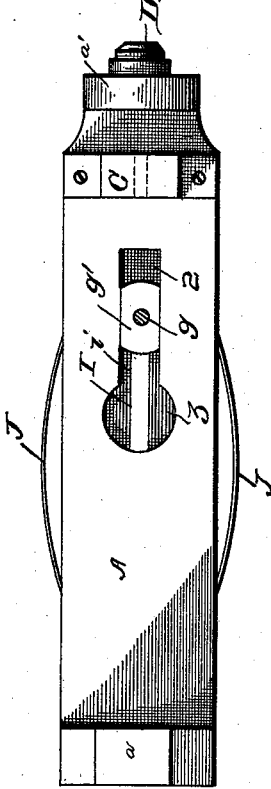

Fig. 5.

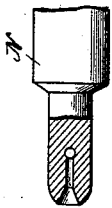

Fig. 6.

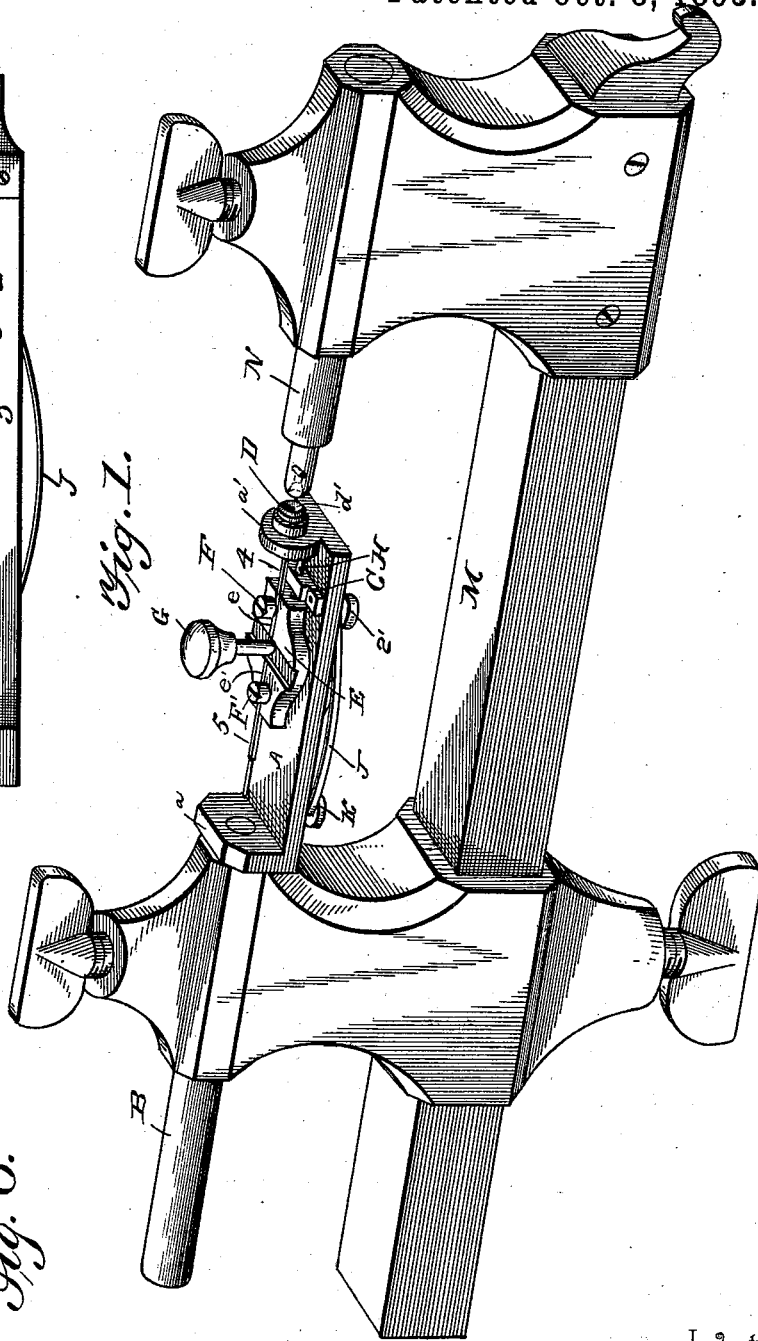

Fig. 1.

Inventor
Martin Leist

Witnesses

E. H. Brown
J. K. Siggers

By *W. S.* Attorneys.

C. A. Snow & Co.

M. LEIST.

AUTOMATIC CENTERING OR PIVOTING DRILL.

No. 547,726.

Patented Oct. 8, 1895.

Fig. 2.

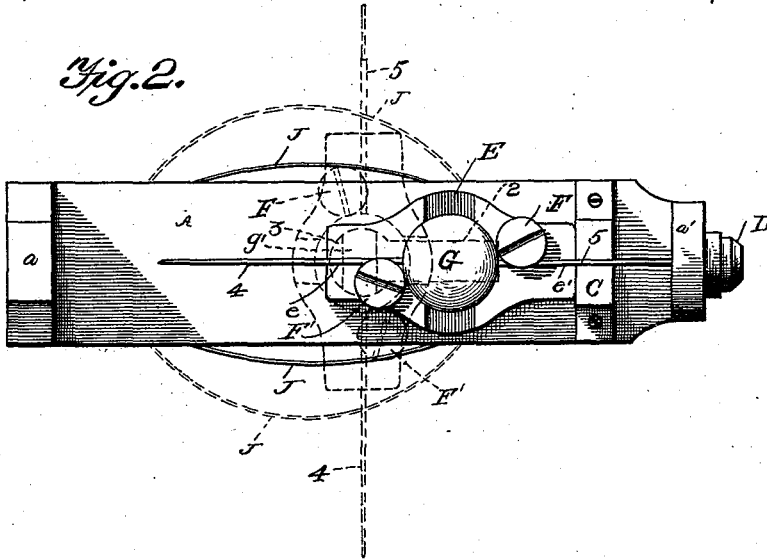

Fig. 3.

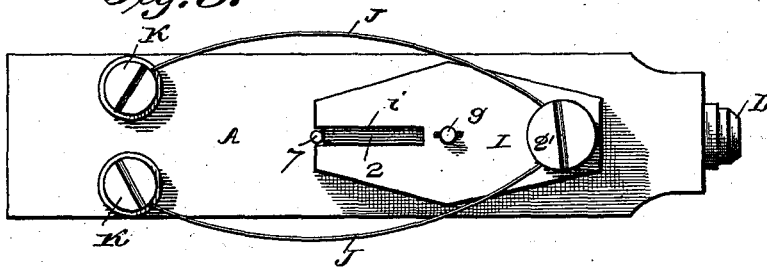
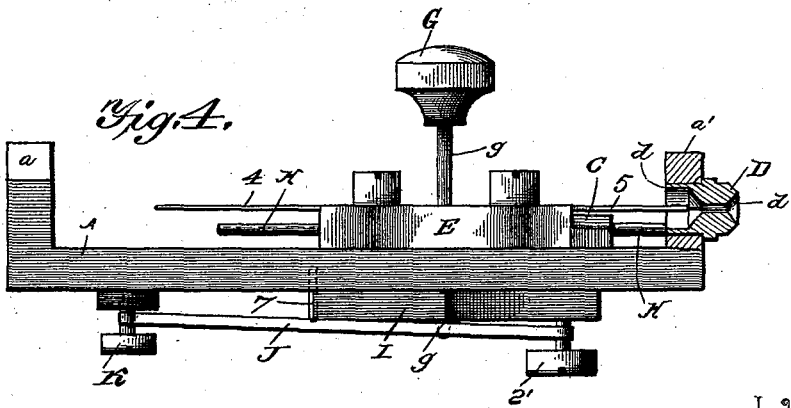

Fig. 4.



Inventor
Martin Leist.

Witnesses

E. H. Monroe
J. H. Siggard

By *his* Attorneys,

C. Brown & Co.

UNITED STATES PATENT OFFICE.

MARTIN LEIST, OF MAITLAND, ASSIGNOR OF ONE-HALF TO NORMAN GENTLE,
OF NORTH SIDNEY, CANADA.

AUTOMATIC CENTERING OR PIVOTING DRILL.

SPECIFICATION forming part of Letters Patent No. 547,726, dated October 8, 1895.

Application filed April 17, 1895. Serial No. 546,051. (No model.)

To all whom it may concern:

Be it known that I, MARTIN LEIST, a citizen of the United States, residing at Maitland, in the county of Hants and Province of Nova Scotia, Canada, have invented a new and useful Automatic Centering or Pivoting Drill, of which the following is a specification.

My invention relates to new and useful improvements in automatic centering and pivoting drills especially designed for watch-makers, and to be used in connection with the Swiss lathes or other forms of lathes in general use among watch and clock repairers. The difficulty experienced by watch-repairers in accurately boring staffs and posts to provide them with new pivots has caused the repairer to discard such parts, thereby resulting in delays in procuring new parts, besides the attending costs.

The purpose of the present invention is the provision of a tool which can be operated by any watchmaker and which will perform the required work in a rapid, accurate, and efficient manner, and which will obviate the spoiling of the work by drilling too deep, as the drill can be set to bore a given depth, which, when reached, the drill can bore no deeper, although the lathe be operated.

With these and such other objects as pertain to the structural organization of the invention, the improvement consists of the novel construction of tool and its component parts, which hereinafter will be more particularly set forth and claimed, and which are shown in the annexed drawings, in which—

Figure 1 is a perspective view showing the application of the invention. Fig. 2 is a top plan view of the tool, showing the operation of the slide by dotted lines. Fig. 3 is a bottom plan view, and Fig. 4 is a side view, of the tool, parts being broken away in the latter view to show the centering-head more clearly. Fig. 5 is a top plan view of a portion of the stock, showing the slot therein and the hub or boss working in the said slot. Fig. 6 is an enlarged view of the end portion of the counter-brooch, a part being broken away to show the opening for the reception of the pivots.

The stock or bed A has lugs a a' at its ends, a brooch or stem B being secured in the lug a , and the lug a' being apertured to receive

the centering-head D, which is removably fitted therein and has a central bar corresponding approximately to the size of the drill. The inner end of the centering-head 55 has a recess d , which forms an oil-cup, and the outer end has a corresponding inwardly-flared recess d' to centralize the part to be bored. Between the lugs a and a' the stock has a longitudinal slot 2, which is circularly enlarged 60 at the end remote from the centering-head to permit the reversing of the slides when drawn back to disengage the drill or centering-point from the centering-head, as will more fully appear hereinafter. A stop C is provided near 65 one end of the stock to arrest the forward movement of the slides and the drill. The upper slide or block E has aligning grooves e e' , which form seats for the reception of the drill 4 and the centering-point 5, which are adjust- 70 ably held in place by binding-screws F F'. A pin or stem g passes through the slide E and the slot 2 and turns with the said slide E when reversing its position. A hub or boss g' , secured upon the pin g , operates in the slot 2, 75 and is of oblong form with rounding ends, so as to turn in the enlarged part 3 of the slot, but of sufficient width, so as to touch the parallel walls of the slot 2 when reciprocating the said slide. Guide-pins H project from 80 the opposite ends of the slide and operate in a suitable opening provided in the stop C. A lower slide I, disposed on the reverse side of the stock, is mounted on the projecting end of the stem g , the latter turning therein, and 85 has a projection 2' at one end to receive the thrust of two bow-springs J, and a slot i at the opposite end to receive a guide-pin 7, extending from the stock. These bow-springs J are attached at one end to projections K of 90 the stock and at the opposite ends have attachment with the slide I by means of the projection 2' and serve to advance the drill to its work by pressing the slides E and I forward as the drill advances to its work. 95

When using the invention, the tool is placed in one head of a lathe, as M, and is held therein by means of the stem B, and a counter-brooch N is placed in the other head. The slides are drawn back by means of a knob G 100 on the stem g until the part g' reaches the enlarged part 3 of the slot, when the slide E is

turned and is held in such position against the action of the springs J by means of the part *g'*, setting crosswise of the slot 2. The part to be drilled is placed between the head D and the brooch N, which are adjusted to hold the work firmly. The slide is turned to bring the centering-point in position to center the work, the slide being allowed to advance gently until the point is in contact with and performs its work on the piece to be drilled. The slide is again drawn back and reversed to bring the drill in operative position, which is allowed to advance gently until it comes in contact with the work, when the drilling is performed in the usual manner by means of a bow, or in any desired way. After the drilling is performed the work is removed and the bore will be found accurate to receive the pivot.

Changes in the form, proportion, and the minor details of construction may be resorted to without departing from the principle or sacrificing any of the advantages of this invention.

It will be understood that the counter-brooch N will be recessed in the end opposite the head D, so as to receive the pivots of staffs or arbors without causing injury thereto when operating upon the same to replace broken pivots. This is clearly indicated in Fig. 1 of the drawings and most especially in the detail view, Fig. 6.

Having thus described the invention, what is claimed as new, and desired to be secured by Letters Patent, is—

1. A centering and drilling tool comprising a stock having a centering head at one end, a slide reversibly mounted upon the stock and provided with a drill and a centering point at opposite ends, each of which is capable of being brought into operative relation, and a spring for pressing the slide for-

ward in either one of its adjusted positions, substantially as described.

2. A centering and drilling tool comprising a stock having a centering head, a reversible slide carrying a drill and a centering point adjustably connected therewith, and a stop to limit the forward movement of the slide, substantially as described.

3. A centering and drilling tool comprising a stock having a centering head, a slide reversibly mounted upon the stock and carrying a drill and a centering point, a stop to limit the forward movement of the slide, and guide-pins carried by the slide and adapted to work in the said stop, substantially as described.

4. A stock having a longitudinal slot enlarged at one end, in combination with a reversible slide carrying a drill and centering point, and a stem secured to the said slide and having an oblong boss to operate in the said slot, substantially as described for the purpose specified.

5. In combination, a stock having a centering head at one end, and having a longitudinal slot enlarged at the end remote from the centering head, a reversible slide carrying the drill and the centering point, a second slide on the reverse side of the stock operated upon by spring pressure, and a stem connecting the said two slides, loosely mounted in the second slide and turning with the reversible slide, and having an oblong boss or hub to operate in the said slot, substantially as specified.

In testimony that I claim the foregoing as my own I have hereto affixed my signature in the presence of two witnesses.

MARTIN LEIST.

Witnesses:

WILLIAM CURRIE,
WILLIAM CHAMBERS.